

# 16-Bit Stereo Audio D/A Converter

## Features

- Wide supply voltage range: 2.4V~5.5V
- CMOS technology
- Low power consumption
- Two voltage output channel in the same chip
- 16-bit dynamic range
- Low total harmonic distortion
- Data in 2's complement format, TTL
- 8-pin SOP package

## Applications

- CD ROM/VCD
- MP3/PDA/Smartphone
- Digital portable audio equipment
- Satellite/cable STB
- Motherboard/MPEG card

## General Description

HT82V731 is a 16-bit digital-to-analog converter IC utilizing CMOS technology specially designed for stereo audio application. It converts the 16 bits serial data into an analog output voltage by high precision D/A converter.

With its excellent frequency response characteristics, the HT82V731 provides users a low cost means of im-

plementing high quality audio voltage outputs. Besides, its wide supply voltage range from 2.4V to 5.5V makes the device also suitable for use in battery-powered systems or in application areas with low current consumption requirements. It is compatible with TDA1311 and available in 8-pin SOP package.

## Block Diagram

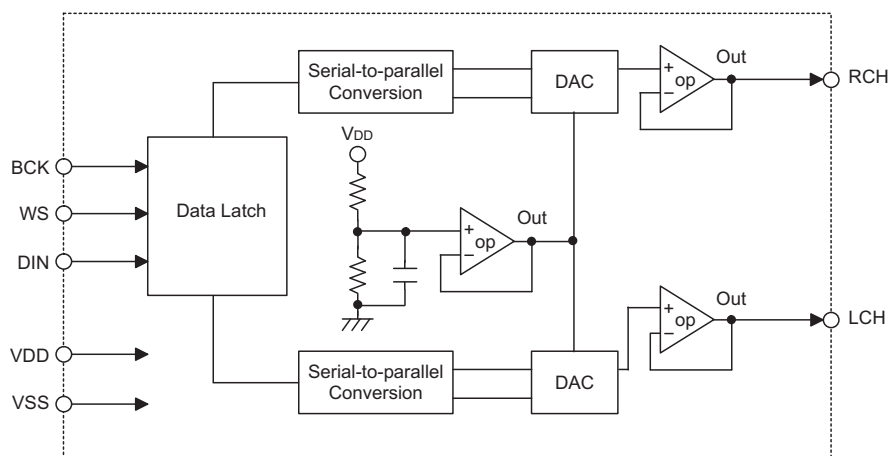

## Pin Assignment

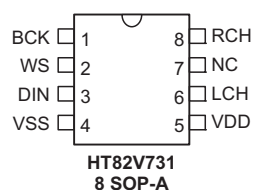

**Pin Description**

Pin No.	Pin Name	I/O	Description
1	BCK	I	Bit serial clock input
2	WS	I	Word select input
3	DIN	I	Data input
4	VSS	—	Negative power supply, ground
5	VDD	—	Positive power supply
6	LCH	O	Left channel output
7	NC	—	No connection
8	RCH	O	Right channel output

**Electrical Characteristics**

Ta=25°C

Symbol	Parameter	Test Conditions		Min.	Typ.	Max.	Unit
		V <sub>DD</sub>	Conditions				
V <sub>DD</sub>	Supply Voltage	—	—	2.4	5.0	5.5	V
I <sub>DD</sub>	Supply Current	5V	—	—	—	6.0	mA
V <sub>O</sub>	Maximum Output Amplitude	5V	—	—	2.5	—	V <sub>pp</sub>
V <sub>IH</sub>	High-level Input Voltage	5V	—	0.7V <sub>DD</sub>	—	V <sub>DD</sub>	V
		3V					
V <sub>IL</sub>	Low-level Input Voltage	5V	—	0	—	0.3V <sub>DD</sub>	V
		3V					
f <sub>BCK</sub>	Bit Clock Input Frequency	—	—	—	—	18.4	MHz
f <sub>WS</sub>	Word Select Input Frequency	—	—	—	—	300	kHz
THD	Total Harmonic Distortion	5V	1kHz, 0dB*	—	65	—	dB
				—	0.055	—	%
DR	Dynamic Range	5V	—	—	16	—	Bit
S/N	Signal to Noise Ratio	5V	A weighted at DIN code=0000H	—	92	—	dB

Note: "\*" means measured with 1kHz sinewave generated at a sampling rate of 192kHz.

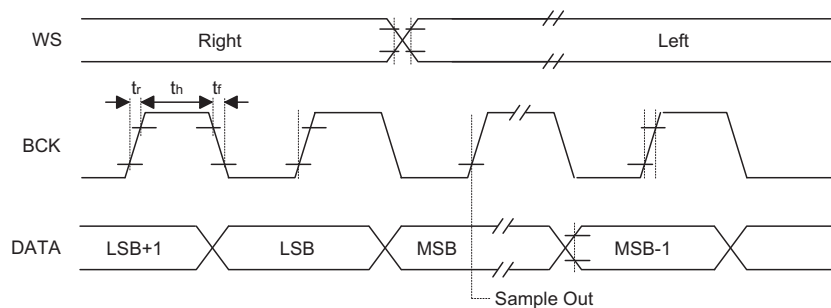
**Timing Diagrams**

**Timing and Input Signals**

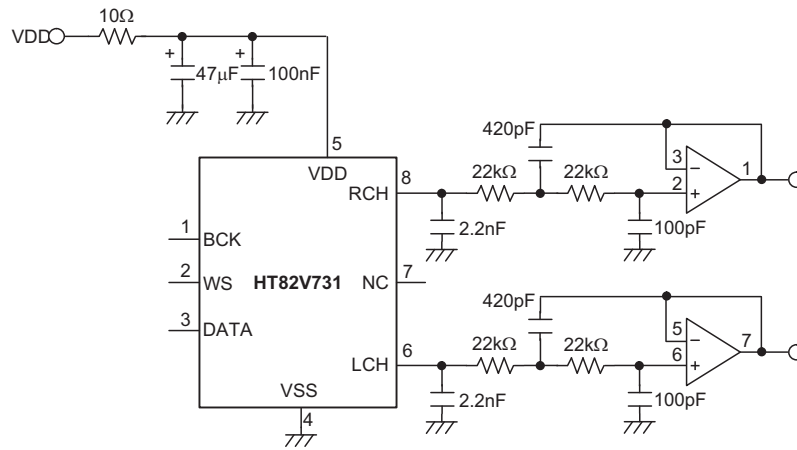
Application Circuits

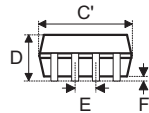
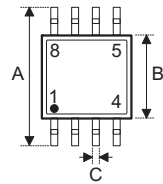

**Package Information**
**8-pin SOP (150mil) Outline Dimensions**

• MS-012

Symbol	Dimensions in inch		
	Min.	Nom.	Max.
A	0.228	—	0.244
B	0.150	—	0.157
C	0.012	—	0.020
C'	0.188	—	0.197
D	—	—	0.069
E	—	0.050	—
F	0.004	—	0.010
G	0.016	—	0.050
H	0.007	—	0.010
$\alpha$	0°	—	8°

Symbol	Dimensions in mm		
	Min.	Nom.	Max.
A	5.79	—	6.20
B	3.81	—	3.99
C	0.30	—	0.51
C'	4.78	—	5.00
D	—	—	1.75
E	—	1.27	—
F	0.10	—	0.25
G	0.41	—	1.27
H	0.18	—	0.25
$\alpha$	0°	—	8°

**Product Tape and Reel Specifications**

**Reel Dimensions**

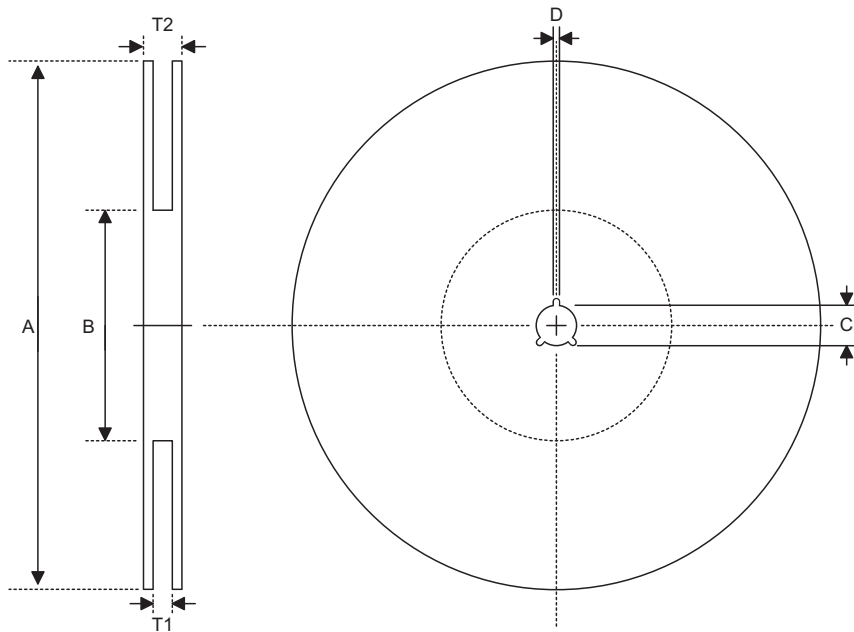

SOP 8N

Symbol	Description	Dimensions in mm
A	Reel Outer Diameter	330.0±1.0
B	Reel Inner Diameter	100.0±1.5
C	Spindle Hole Diameter	13.0 <sup>+0.5/-0.2</sup>
D	Key Slit Width	2.0±0.5
T1	Space Between Flange	12.8 <sup>+0.3/-0.2</sup>
T2	Reel Thickness	18.2±0.2

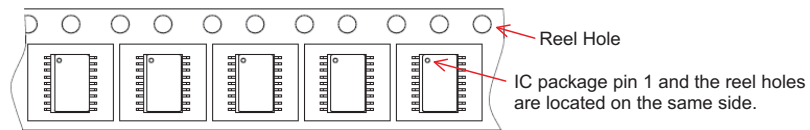
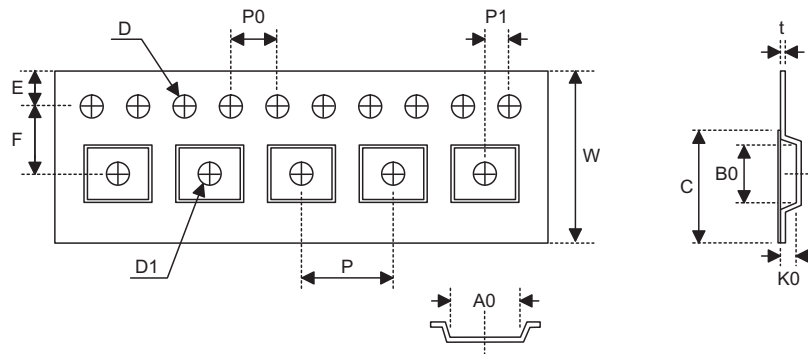
**Carrier Tape Dimensions**

**SOP 8N**

Symbol	Description	Dimensions in mm
W	Carrier Tape Width	12.0 <sup>+0.3/-0.1</sup>
P	Cavity Pitch	8.0±0.1
E	Perforation Position	1.75±0.1
F	Cavity to Perforation (Width Direction)	5.5±0.1
D	Perforation Diameter	1.55±0.1
D1	Cavity Hole Diameter	1.50 <sup>+0.25/-0.00</sup>
P0	Perforation Pitch	4.0±0.1
P1	Cavity to Perforation (Length Direction)	2.0±0.1
A0	Cavity Length	6.4±0.1
B0	Cavity Width	5.2±0.1
K0	Cavity Depth	2.1±0.1
t	Carrier Tape Thickness	0.30±0.05
C	Cover Tape Width	9.3±0.1

**Holtek Semiconductor Inc. (Headquarters)**

No.3, Creation Rd. II, Science Park, Hsinchu, Taiwan  
Tel: 886-3-563-1999  
Fax: 886-3-563-1189  
<http://www.holtek.com.tw>

**Holtek Semiconductor Inc. (Taipei Sales Office)**

4F-2, No. 3-2, YuanQu St., Nankang Software Park, Taipei 115, Taiwan  
Tel: 886-2-2655-7070  
Fax: 886-2-2655-7373  
Fax: 886-2-2655-7383 (International sales hotline)

**Holtek Semiconductor Inc. (Shenzhen Sales Office)**

5F, Unit A, Productivity Building, No.5 Gaoxin M 2nd Road, Nanshan District, Shenzhen, China 518057  
Tel: 86-755-8616-9908, 86-755-8616-9308  
Fax: 86-755-8616-9722

**Holtek Semiconductor (USA), Inc. (North America Sales Office)**

46729 Fremont Blvd., Fremont, CA 94538  
Tel: 1-510-252-9880  
Fax: 1-510-252-9885  
<http://www.holtek.com>

Copyright © 2011 by HOLTEK SEMICONDUCTOR INC.

The information appearing in this Data Sheet is believed to be accurate at the time of publication. However, Holtek assumes no responsibility arising from the use of the specifications described. The applications mentioned herein are used solely for the purpose of illustration and Holtek makes no warranty or representation that such applications will be suitable without further modification, nor recommends the use of its products for application that may present a risk to human life due to malfunction or otherwise. Holtek's products are not authorized for use as critical components in life support devices or systems. Holtek reserves the right to alter its products without prior notification. For the most up-to-date information, please visit our web site at <http://www.holtek.com.tw>.