

Features

- Operating voltage: 3.3V
- Low power consumption at 56mW
- Power-down mode: Under 1 μ A (clock timing keep low)
- 16-bit 6 MSPS A/D converter
- Guaranteed no missing codes
- Supports CDS/SHA mode
- 1~6 programmable gain
- ± 200 mV programmable offset
- Input clamp circuitry
- Internal voltage reference
- Multiplexed byte-wide output (8+8 format)
- Programmable 3-wire serial interface
- 3.3V digital I/O compatibility
- 28-pin SSOP (209mil) package

Applications

Low power flatbed document scanners

General Description

The HT82V36 is a complete analog signal processor for CCD imaging applications. It features a 1-channel architecture designed to sample and condition the outputs of linear CCD arrays. It consists of an input clamp, Correlated Double Sampler (CDS), offset DAC and Programmable Gain Amplifier (PGA), and a low power 16-bit A/D converter.

The CDS amplifiers may be disabled for use with sensors such as Contact Image Sensors (CIS) and CMOS active pixel sensors, which do not require CDS.

The 16-bit digital output is multiplexed into an 8-bit output word that is accessed using two read cycles. The internal registers are programmed through a 3-wire serial interface, which provides gain, offset and operating mode adjustments.

Block Diagram

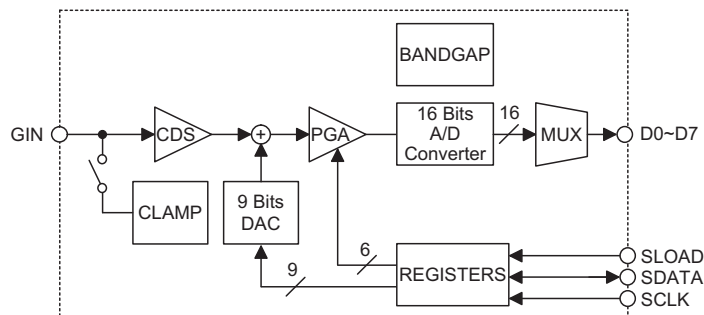

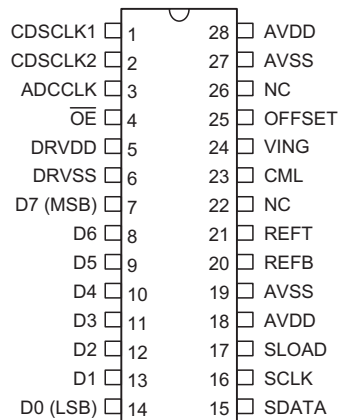
Pin Assignment

**HT82V36
- 28 SSOP-A**

Pin Description

Pin No.	Pin Name	I/O	Description
1	CDSCLK1	DI	CDS reference clock pulse input
2	CDSCLK2	DI	CDS data clock pulse input
3	ADCCLK	DI	A/D sample clock input
4	\overline{OE}	DI	Output enable, active low
5	DRVDD	P	Digital driver power
6	DRVSS	P	Digital driver ground
7~14	D7~D0	DO	Digital data output
15	SDATA	DI/DO	Serial data input/output
16	SCLK	DI	Clock input for serial interface
17	SLOAD	DI	Serial interface load pulse
18, 27	AVSS	P	Analog ground
19, 28	AVDD	P	Analog supply
20	REFB	AO	Reference decoupling
21	REFT	AO	Reference decoupling
23	CML	AO	Internal reference output
24	VING	AI	Analog input
25	OFFSET	AO	Clamp bias level decoupling
22, 26	NC	—	No connection

Absolute Maximum Ratings

Supply Voltage	$V_{SS}-0.3V$ to $V_{SS}+3.6V$	Storage Temperature	$-50^{\circ}C$ to $125^{\circ}C$
Input Voltage	$V_{SS}-0.3V$ to $V_{DD}+0.3V$	Operating Temperature	$-25^{\circ}C$ to $75^{\circ}C$

Note: These are stress ratings only. Stresses exceeding the range specified under "Absolute Maximum Ratings" may cause substantial damage to the device. Functional operation of this device at other conditions beyond those listed in the specification is not implied and prolonged exposure to extreme conditions may affect device reliability.

D.C. Characteristics

Symbol	Parameter	Test Conditions		Min.	Typ.	Max.	Unit
		V _{DD}	Conditions				
Logic Inputs							
V _{IH}	High Level Input Voltage	—	—	0.8×V _{DD}	—	—	V
V _{IL}	Low Level Input Voltage	—	—	—	—	0.2×V _{DD}	V
I _{IH}	High Level Input Current	—	—	—	10	—	μA
I _{IL}	Low Level Input Current	—	—	—	10	—	μA
C _{IN}	Input Capacitance	—	—	—	10	—	pF
Logic Outputs							
V _{OH}	High Level Output Voltage	—	—	V _{DD} -0.5	—	—	V
V _{OL}	Low Level Output Voltage	—	—	—	—	0.5	V
I _{OH}	High Level Output Current	—	—	—	1	—	mA
I _{OL}	Low Level Output Current	—	—	—	1	—	mA

A.C. Characteristics

Symbol	Parameter	Test Conditions		Min.	Typ.	Max.	Unit
		V _{DD}	Conditions				
Maximum Conversion Rate							
t _{MAX}	CDS/SHA Mode	—	—	6	—	—	MHz
Accuracy (Entire Signal Path)							
	ADC Resolution	—	—	—	16	—	
	Integral Nonlinear (INL)	—	—	—	±16	—	LSB
	Differential Nonlinear (DNL)	—	—	-1	—	2	LSB
	Offset Error	—	—	-100	TBD	100	mV
	Gain Error	—	—	—	TBD	—	%FSR
Analog Inputs							
R _{FS}	Full-scale Input Range	—	—	1.3	1.4	1.6	V _{p-p}
V _i	Input Limits	—	—	AV _{DD} -0.3	—	AV _{DD} +0.3	V
C _i	Input Capacitance	—	—	—	TBD	—	pF
I _i	Input Current	—	—	—	TBD	—	μA
Amplifiers							
	PGA Gain at Minimum	—	—	—	1	—	V/V
	PGA Gain at Maximum	—	—	—	5.85	—	V/V
	PGA Gain Resolution	—	—	—	6	—	Bits
	Programmable Offset at Minimum	—	—	—	-200	—	mV
	Programmable Offset at Maximum	—	—	—	200	—	mV
	Offset Resolution	—	—	—	9	—	Bits
Temperature Range							
t _A	Operating	—	—	0	—	70	°C
Power Supplies							
V _{ADD}	AV _{DD}	—	—	3	3.3	3.6	V
V _{DRDD}	DR _{VDD}	—	—	3	3.3	3.6	V
Power Consumption							
P _{tot}	Total Power Consumption	—	—	—	56	—	mW

Timing Specification

Symbol	Parameter	Min.	Typ.	Max.	Unit
Clock Parameters					
t_{ADCLK}	Pixel Rate Clock	166	—	—	ns
t_{ADH}	ADCCLK Pulse High Width	80	—	—	ns
t_{ADL}	ADCCLK Pulse Low Width	80	—	—	ns
t_{C1}	CDSCLK1 Pulse Width	20	—	—	ns
t_{C2}	CDS Mode CDSCLK2 Pulse Width	20	—	—	ns
t_{C3}	SHA Mode CDSCLK2 Pulse Width	40	—	—	ns
t_{C2ADF}	CDSCLK2 Falling to ADCCLK Falling	60	—	—	ns
t_{ADFC1}	ADCCLK Falling to CDSCLK1 Rising	2	—	—	ns
t_{ADFC2}	ADCCLK Falling to CDSCLK2 Rising	2	—	—	ns
t_{AD}	Analog Sampling Delay	5	—	—	ns
Serial Interface					
f_{SCLK}	Maximum SCLK Frequency	10	—	—	MHz
t_{LS}	SLOAD to SCLK Setup Time	10	—	—	ns
t_{LH}	SCLK to SLOAD Hold Time	10	—	—	ns
t_{DS}	SDATA to SCLK Rising Setup Time	10	—	—	ns
t_{DH}	SCLK Rising to SDATA Hold Time	10	—	—	ns
t_{RDV}	Falling to SDATA Valid	10	—	—	ns
Data Output					
t_{OD}	Output Delay	—	8	—	ns
	Latency (Pipeline Delay)	—	9	—	Cycles

Functional Description
Integral Nonlinear (INL)

Integral nonlinear error refers to the deviation of each individual code from a line drawn from zero scale through positive full scale. The point used as zero scale occurs 1/2 LSB before the first code transition. Positive full scale is defined as a level 1/2 LSB beyond the last code transition. The deviation is measured from the middle of each particular code to the true straight line.

Differential Nonlinear (DNL)

An ideal ADC exhibits code transitions that are exactly 1 LSB apart. DNL is the deviation from this ideal value. Thus every code must have a finite width. No missing codes guaranteed to 16-bit resolution indicates that all 4096 codes, respectively, must be present over all operating ranges.

Offset Error

The first ADC code transition should occur at a level 1/2 LSB above the nominal zero scale voltage.

The offset error is the deviation of the actual first code transition level from the ideal level.

Gain Error

The last code transition should occur for an analog value 1/2 LSB below the nominal full-scale voltage.

Gain error is the deviation of the actual difference between first and last code transitions and the ideal difference between the first and last code transitions.

Aperture Delay

The aperture delay is the time delay that occurs when a sampling edge is applied to the HT82V36 until the actual sample of the input signal is held. Both CDSCLK1 and CDSCLK2 sample the input signal during the transition from high to low, so the aperture delay is measured from each clock's falling edge to the instant the actual internal sample is taken.

Internal Register Descriptions

Register Name	Address			Data Bits								
	A2	A1	A0	D8	D7	D6	D5	D4	D3	D2	D1	D0
Configuration	0	0	0	0	0	1	1	CDS on	Clamp Voltage	Enable Power Down	Output Delay	1byte out
Reserved	0	0	1									
Reserved	0	1	0									
PGA	0	1	1	X	0	0	MSB					LSB
Reserved	1	0	0									
Reserved	1	0	1									
Offset	1	1	0	MSB								LSB
Reserved	1	1	1									

Internal Register Map

D8	D7	D6	D5	D4	D3	D2	D1	D0
Set to 0	Set to 0	Set to 1	Set to 1	CDS operation 1=CDS mode* 0=SHA mode	Clamp bias 1=2.5V* 0=2V	Power-down 1=On 0=Off (Normal)*	Output delay 1=On 0=Off*	1 byte out (High-byte only) 1=On 0=Off*

Configuration Register Settings

Note: * Power-on default value

PGA Gain Register

Bits D7 and D6 in the register must be set low, and bits D5 through D0 control the gain range in 64 increments. See figure for a graph of the PGA gain versus PGA register code. The coding for the PGA register is straight binary, with an all zero words corresponding to the minimum gain setting (1x) and an all one word corresponding to the maximum gain setting (5.85x).

The PGA has a gain range from 1x (0dB) to 5.85x (15.3dB), adjustable in 64 steps. The Figure shows the PGA gain as a function of the PGA register code. Although the gain curve is approximately linear in dB, the gain in V/V varies in non-linear proportion with the register code, according to the following the equation:

$$\text{Gain} = \frac{5.85}{1 + 4.85 \times \left(\frac{63 - G}{63}\right)}$$

Where G is the decimal value of the gain register contents, and varies from 0 to 63.

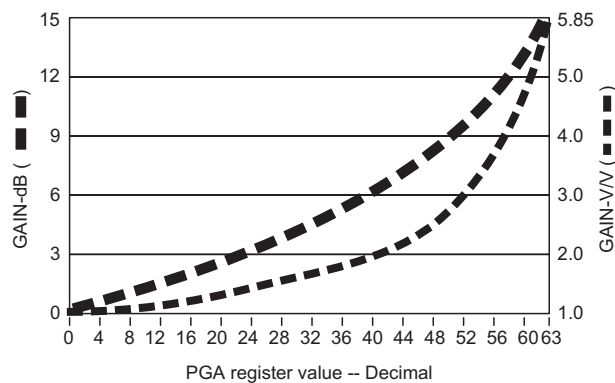
PGA Gain Transfer Function

D8	D7	D6	D5	D4	D3	D2	D1	D0	Gain (V/V)	Gain (dB)
Set to 0	Set to 0	Set to 0	MSB					LSB		
0	0	0	0	0	0	0	0	0*	1.0	0.0
0	0	0	0	0	0	0	0	1	1.013	0.12
									⋮	⋮
0	0	0	1	1	1	1	1	0	5.43	14.7
0	0	0	1	1	1	1	1	1	5.85	15.3

PGA Gain Register Settings

Note: * Power-on default value

Offset Register

Bits D8 through D0 control the offset range from -200mV to 200mV in 512 increments.

The coding for the offset registers is sign magnitude, with D8 as the sign bit. The Table shows the offset range as a function of the bits D8 through D0.

D8	D7	D6	D5	D4	D3	D2	D1	D0	Offset (mV)
MSB								LSB	
0	0	0	0	0	0	0	0	0*	0
0	0	0	0	0	0	0	0	1	0.78
									⋮
0	1	1	1	1	1	1	1	1	200
1	0	0	0	0	0	0	0	0	0
1	0	0	0	0	0	0	0	1	-0.78
									⋮
1	1	1	1	1	1	1	1	1	-200

Note: * Power-on default value

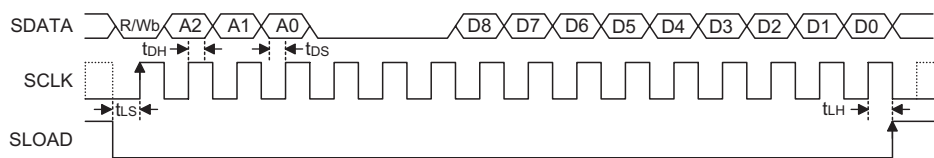
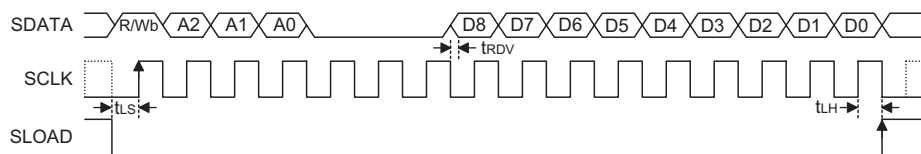
Timing Diagrams

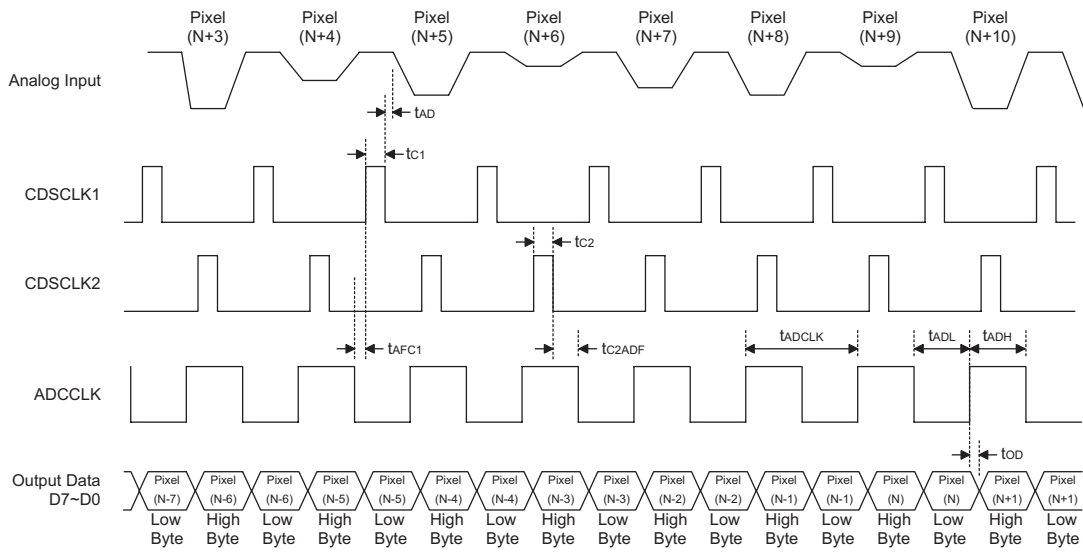
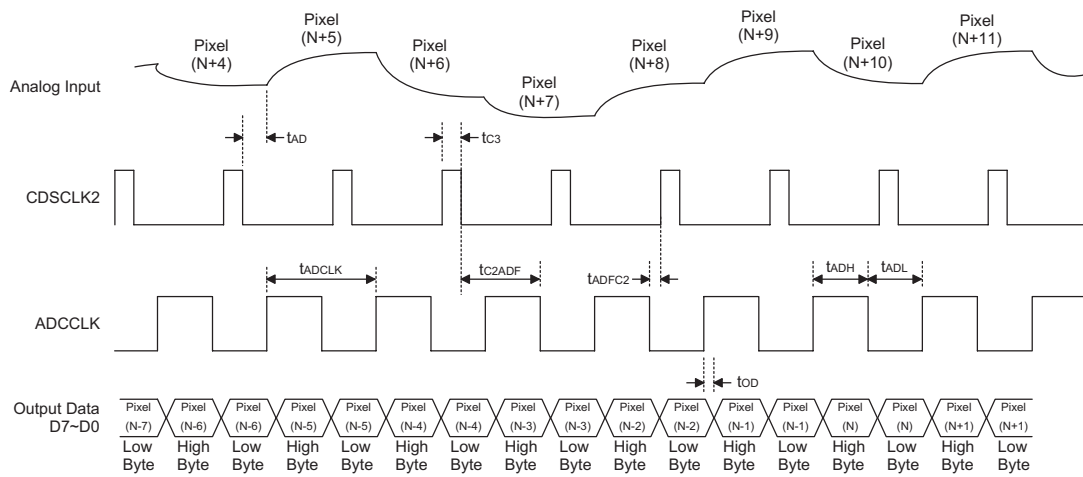
Serial Write Operation Timing

Serial Read Operation Timing



1-Channel CDS Mode Timing

1-Channel SHA Mode Timing

Application Circuits

The recommended circuit configuration for 1-channel CDS mode operation is shown below.

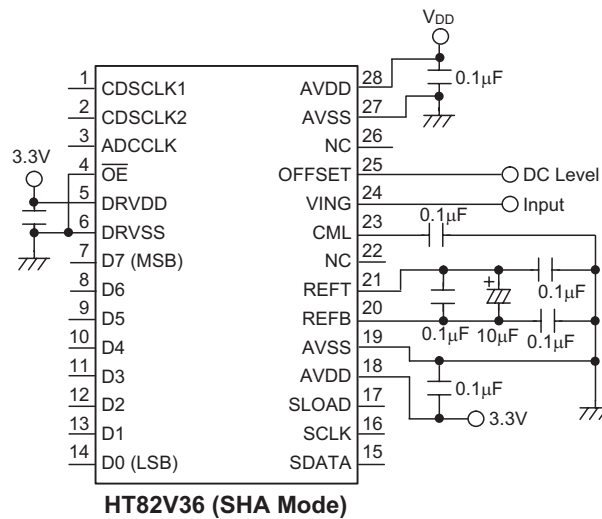
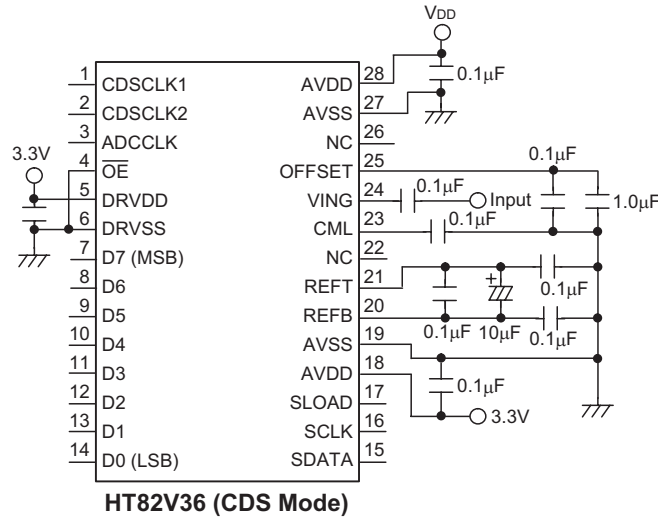
The recommended input coupling capacitor value is 0.1 μ F (see circuit operation section for more details).

A single ground plane is recommended for the HT82V36. A separate power supply may be used for DRVDD, the digital driver supply, but this supply pin should still be decoupled to the same ground plane as the rest of the HT82V36. The loading of the digital outputs should be minimized, either by using short traces to the digital ASIC, or by using external digital buffers. All 0.1 μ F decoupling capacitors should be located as close as possible to the HT82V36 pins.



Note: For the SHA Mode, all of the above considerations also apply, except that the analog input signal is directly connected to the HT82V36 without using a coupling capacitor. The OFFSET pin should be grounded if the input to the HT82V36 is to be referenced to ground, or a dc offset voltage should be applied to the OFFSET pin in situation where a coarse offset needs to be removed from the input.

Package Information

28-pin SSOP (209mil) Outline Dimensions

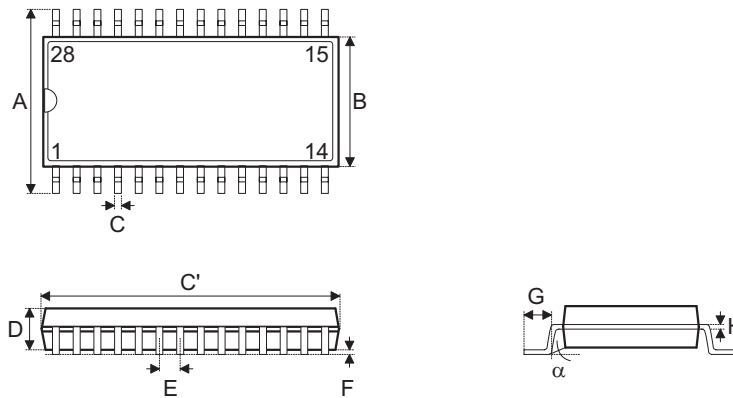

Symbol	Dimensions in mil		
	Min.	Nom.	Max.
A	291	—	323
B	196	—	220
C	9	—	15
C'	396	—	407
D	65	—	73
E	—	25.59	—
F	4	—	10
G	26	—	34
H	4	—	8
α	0°	—	8°

Product Tape and Reel Specifications

Reel Dimensions

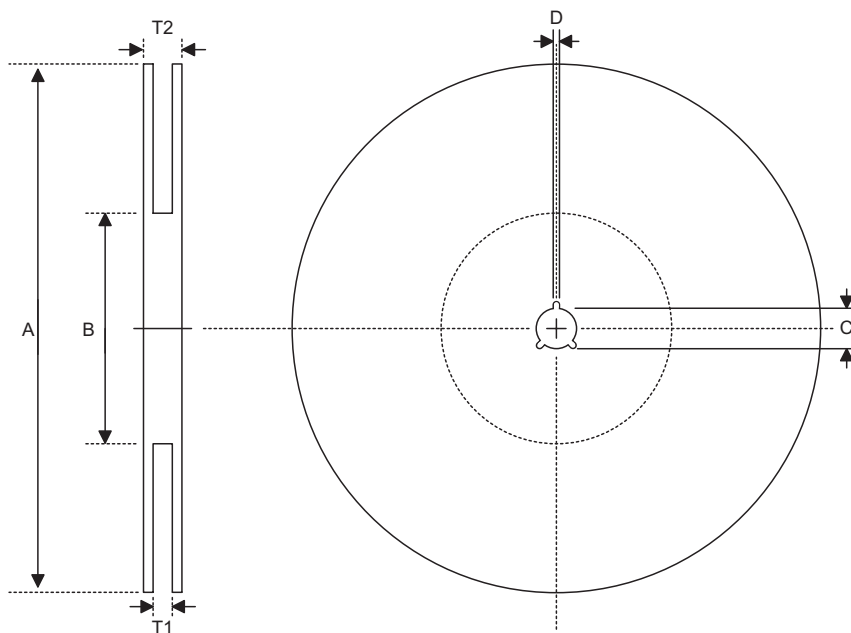

SSOP 28S (209mil)

Symbol	Description	Dimensions in mm
A	Reel Outer Diameter	330.0±1.0
B	Reel Inner Diameter	100.0±1.5
C	Spindle Hole Diameter	13.0 ^{+0.5/-0.2}
D	Key Slit Width	2.0±0.5
T1	Space Between Flange	28.4 ^{+0.3/-0.2}
T2	Reel Thickness	31.1 (max.)

Carrier Tape Dimensions

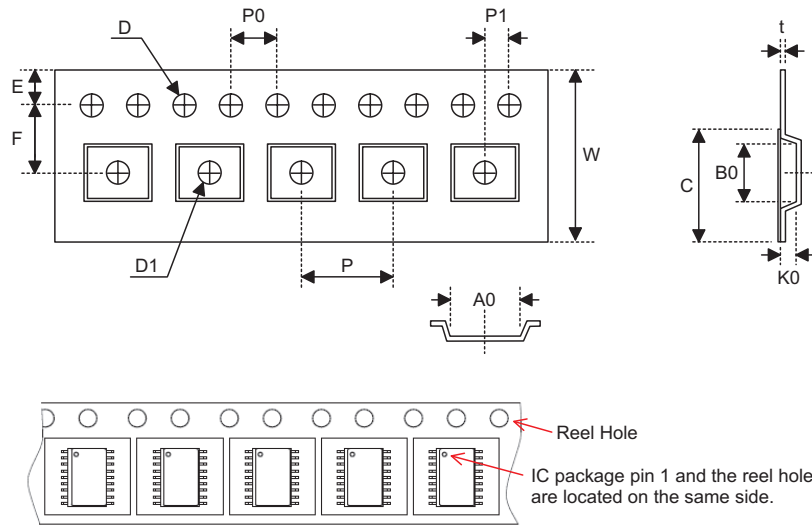

SSOP 28S (209mil)

Symbol	Description	Dimensions in mm
W	Carrier Tape Width	24.0±0.3
P	Cavity Pitch	12.0±0.1
E	Perforation Position	1.75±0.1
F	Cavity to Perforation (Width Direction)	11.5±0.1
D	Perforation Diameter	1.5 ^{+0.1/-0.0}
D1	Cavity Hole Diameter	1.50 ^{+0.25/-0.00}
P0	Perforation Pitch	4.0±0.2
P1	Cavity to Perforation (Length Direction)	2.0±0.1
A0	Cavity Length	8.4±0.1
B0	Cavity Width	10.65±0.10
K0	Cavity Depth	2.4±0.1
t	Carrier Tape Thickness	0.30±0.05
C	Cover Tape Width	21.3±0.1

Holtek Semiconductor Inc. (Headquarters)

No.3, Creation Rd. II, Science Park, Hsinchu, Taiwan
Tel: 886-3-563-1999
Fax: 886-3-563-1189
<http://www.holtek.com.tw>

Holtek Semiconductor Inc. (Taipei Sales Office)

4F-2, No. 3-2, YuanQu St., Nankang Software Park, Taipei 115, Taiwan
Tel: 886-2-2655-7070
Fax: 886-2-2655-7373
Fax: 886-2-2655-7383 (International sales hotline)

Holtek Semiconductor Inc. (Shanghai Sales Office)

G Room, 3 Floor, No.1 Building, No.2016 Yi-Shan Road, Minhang District, Shanghai, China 201103
Tel: 86-21-5422-4590
Fax: 86-21-5422-4705
<http://www.holtek.com.cn>

Holtek Semiconductor Inc. (Shenzhen Sales Office)

5F, Unit A, Productivity Building, Gaoxin M 2nd, Middle Zone Of High-Tech Industrial Park, ShenZhen, China 518057
Tel: 86-755-8616-9908, 86-755-8616-9308
Fax: 86-755-8616-9722

Holtek Semiconductor Inc. (Beijing Sales Office)

Suite 1721, Jinyu Tower, A129 West Xuan Wu Men Street, Xicheng District, Beijing, China 100031
Tel: 86-10-6641-0030, 86-10-6641-7751, 86-10-6641-7752
Fax: 86-10-6641-0125

Holtek Semiconductor Inc. (Chengdu Sales Office)

709, Building 3, Champagne Plaza, No.97 Dongda Street, Chengdu, Sichuan, China 610016
Tel: 86-28-6653-6590
Fax: 86-28-6653-6591

Holtek Semiconductor (USA), Inc. (North America Sales Office)

46729 Fremont Blvd., Fremont, CA 94538, USA
Tel: 1-510-252-9880
Fax: 1-510-252-9885
<http://www.holtek.com>

Copyright © 2008 by HOLTEK SEMICONDUCTOR INC.

The information appearing in this Data Sheet is believed to be accurate at the time of publication. However, Holtek assumes no responsibility arising from the use of the specifications described. The applications mentioned herein are used solely for the purpose of illustration and Holtek makes no warranty or representation that such applications will be suitable without further modification, nor recommends the use of its products for application that may present a risk to human life due to malfunction or otherwise. Holtek's products are not authorized for use as critical components in life support devices or systems. Holtek reserves the right to alter its products without prior notification. For the most up-to-date information, please visit our web site at <http://www.holtek.com.tw>.